

EPAWCS

This pivotal whole home system conditions and filters the water throughout your entire home reducing scale, sediment and chlorine without the use of salt. This system is ideal for all household sizes with either city or well water sources.

FEATURES AND BENEFITS

- Anti-scale media reduces hard water buildup in pipes and fixtures
- Helps maintain the life and performance of water-using appliances
- Water heaters operate 29% more efficiently and last 50% longer[†]
- Doesn't require water softener salt to operate
- Filters out sediment, dirt, rust and sand for cleaner, clearer water throughout your home
- Carbon filtration for better tasting water
- Automatic bypass eliminates need to shutoff household water supply when changing filters

[†]Based on a 2010 WQA study measuring the impact on water heater efficiency with and without hard water scale.



REDUCES



SCALE
BUILDUP



SEDIMENT



CHLORINE
TASTE & ODOR

USES ENCASED FILTERS

Filters utilize FACT[®], activated carbon and polyphosphate media to reduce scale, sediment and chlorine taste and odor throughout the entire home. Sanitary encased design allows you to easily change filters without touching filter media.

- 5 micron
- 6-month filter life



EPAWCF

Salt-Free Whole Home Water Conditioner

EPAWCS



SPECIFICATIONS

Model Number	EPAWCS
Part Number	EPAWCS8
Household Size	All
Uses Filter Model	EPAWCF
Rated Service Flow Rate	9.0 gpm
Pressure Drop Service Flow Rate	13.5 psi
Water Pressure Limit (Min/Max)	30 - 100 psi
Supply Water Temperature	40 - 100°F
Standard Connection Size	1" Male NPT
Dimensions (H x W x D)	17 1/2" x 10 1/8" x 9 7/8"

WARRANTY

2 year parts	•
--------------	---

TYPICAL INSTALLATION

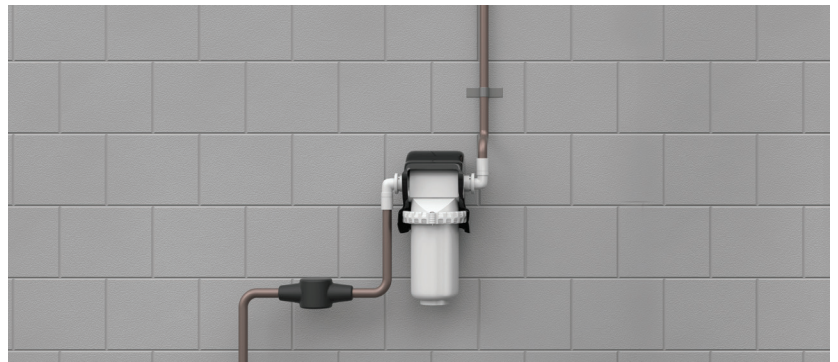
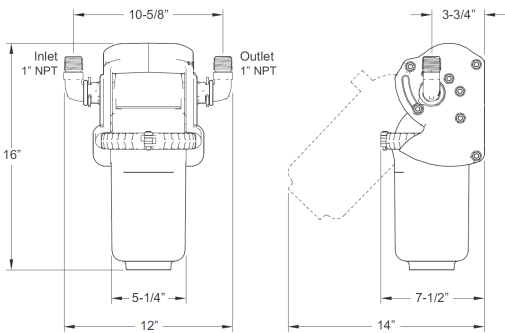

EASY FILTER CHANGE PROCESS

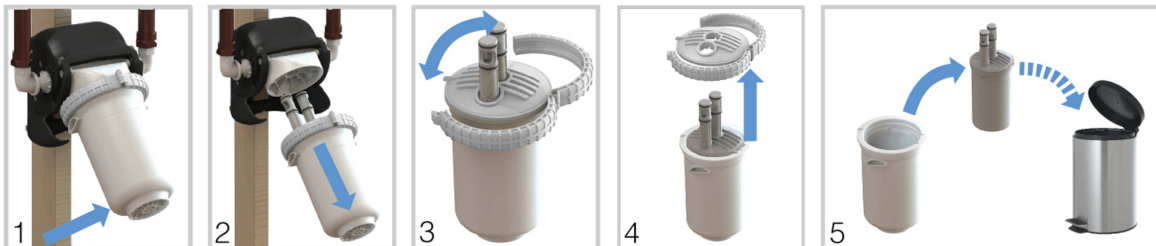

FOR MORE INFORMATION CALL

1-800-693-1138

OR VISIT

www.ecopure.com